

# VRAJLINK

## AUTHORIZED DEALER & DISTRIBUTORS

Address :- Shop No. 17, Opp. Electric Crematorium, 66/74 Chandan Wadi, Marine Lines (E), Mumbai - 400002

Email :- [vrajlink09@gmail.com](mailto:vrajlink09@gmail.com)

Contact :- 9223310978 / 9833935831

Website :- [www.vrajlink.com](http://www.vrajlink.com)



# WOTPC

## Automatic Transfer Switching Equipment

1000A - 4000A series  
Product catalog



[schneider-electric.co.in](http://schneider-electric.co.in)

Life Is On

**Schneider**  
Electric

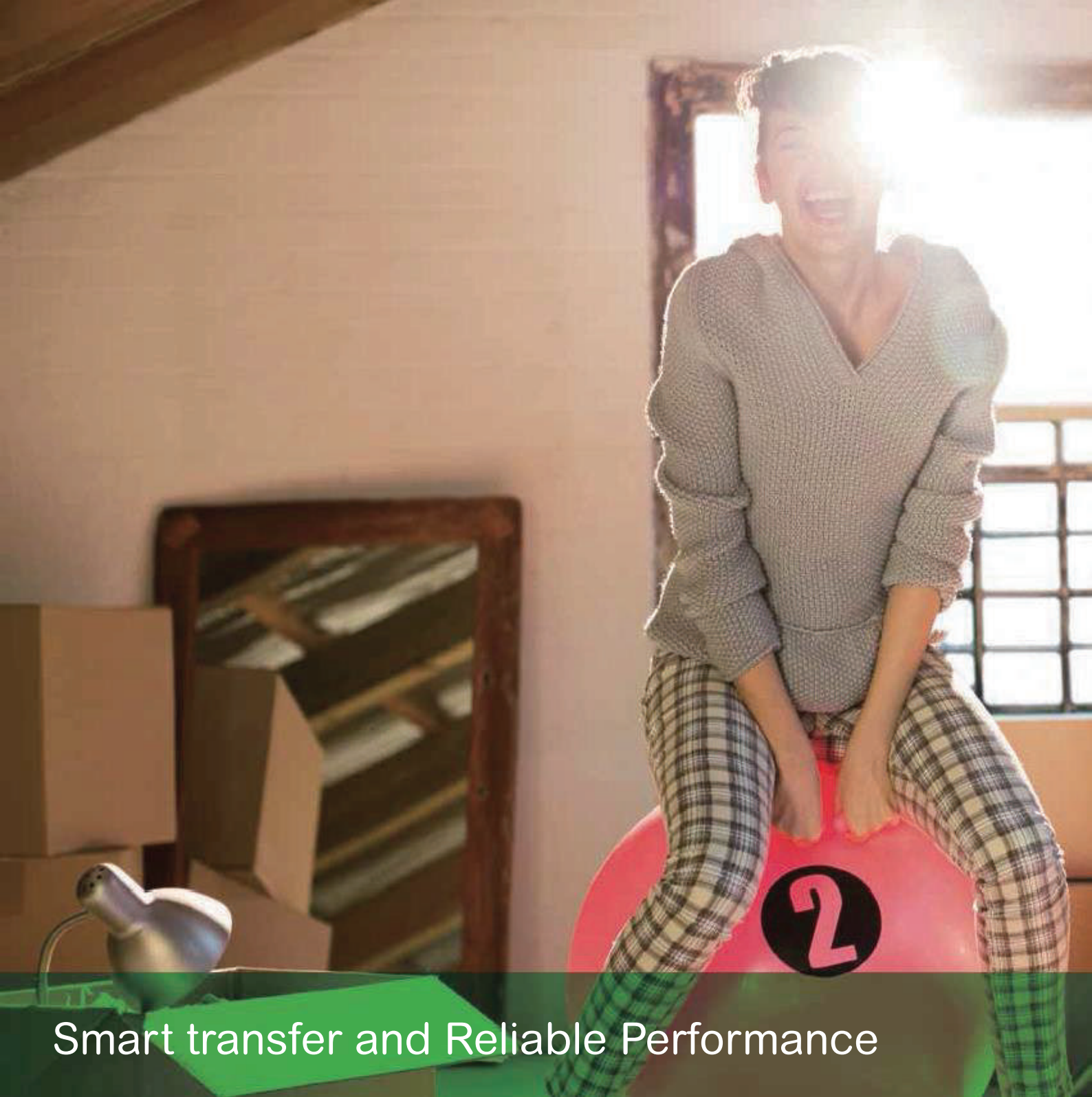

## Smart transfer and Reliable Performance

### WOTPC Automatic transfer switch

- Smart transfer of key power sources based on flexible and convenient control functions
- Safely operation under extreme conditions due to the marvelous EMC (Electromagnetic Compatibility) feature
- Reliable Performance brings to you safely operations – a better short-circuit performance

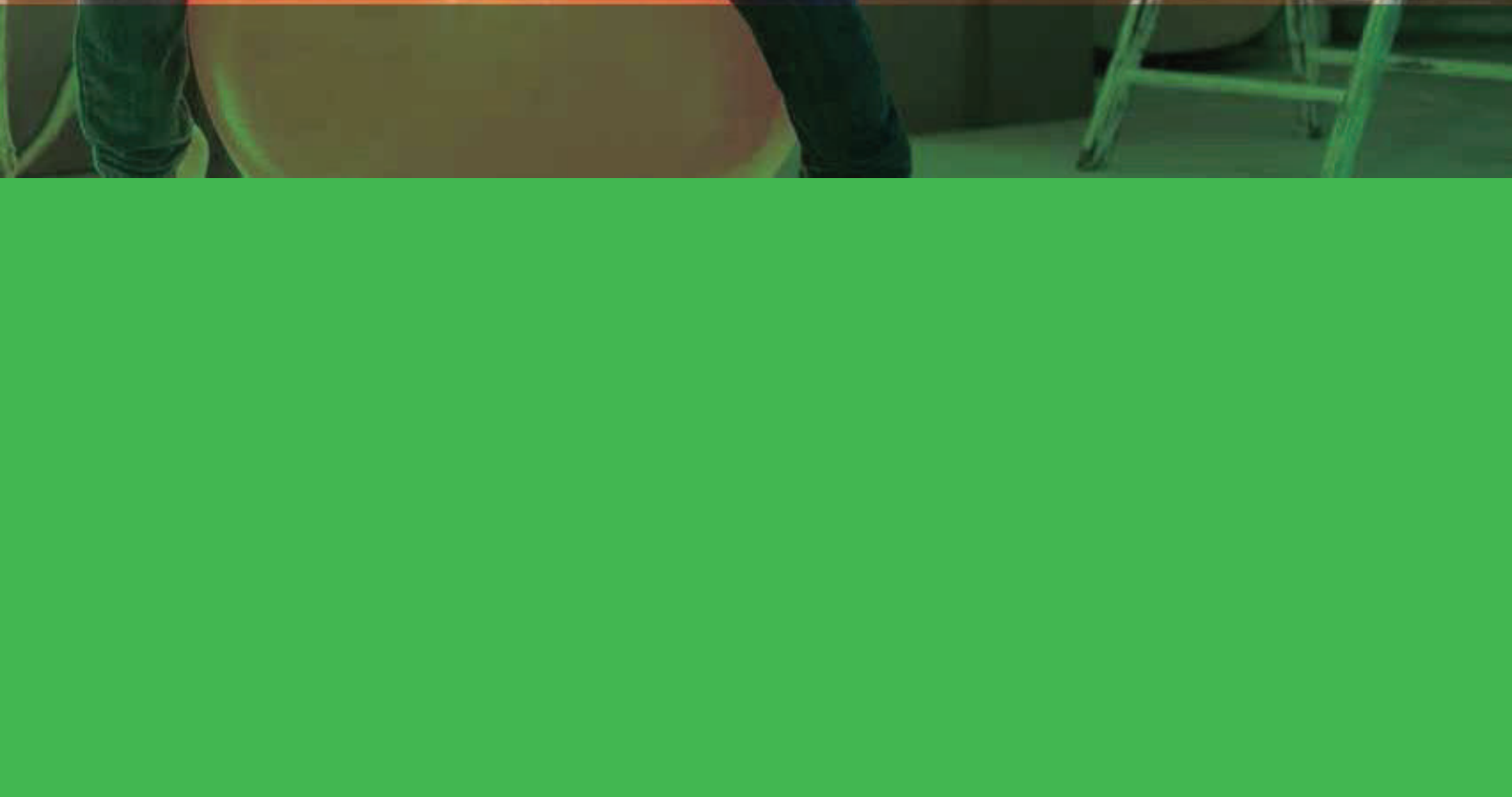

Overview	5
Product Information	5
Electrical Specification	6
Types of Transfer	6
Poles	6
Controller	7
Interlocking	15
Operating Conditions	16
Installation and connection	18
Setup and connect	20
Appendix 1	26

---



WOTPC ATS (Automatic Transfer Switch) is a high-performance PC-Class transferring switch, especially suitable for commercial buildings, industries & infrastructures that require automatic switching of common and standby power sources, apt for Line - Line / Line - Generator / Generator - Generator applications.

Our ATS features a special contact structure and a new generation of solenoid operating coils that can withstand thousands of operating cycles without burning, pitting, or fusion welding. No daily contact maintenance is required, 100% of the rated current can be sustained without "contact" burning and can withstand short circuit current.

Our ATS has a sensible load security transfer for the delay transfer mode.

### Norms

- IEC60947-6-1 Low-voltage switchgear and control equipment: multi-function electrical transfer switch (IEC certified).
- GB/T14048.11-2016 Low-voltage switchgear and control equipment: multi-function electrical transfer switch (CCC certified).

## Product Information

WOTPC ATS consists of three parts:

1. Transfer Switch Unit,
2. Controller, and
3. Controller Cable.

The transfer switch unit relates to the controller through its cable to realize the detection of the power supply. The controller automatically completes the transfer between the power supply through the set program.

### Transfer Switch Unit

- Carry the primary loop current
- Short-circuit tolerance
- Mechanical interlocks provision to ensure that S1 and S2 power supplies do not run side by side
- Manual operation device is provided



Transfer Switch Unit

### Controller

- S1 and S2 power supply quality check
- Power transfer action when the power supply state exceeds the set threshold
- An electrical interlock and a logic protection circuit ensure that S1 and S2 power supplies do not run side by side
- Automatic/controller button transfer and the option to exit the controller's control
- Function of over voltage protection and can work normally for a long time
- Designed to use in the special environment



Controller

### Controller Cable

- Used to realize the transfer function
- Electrical interlocking loops



Controller Cable

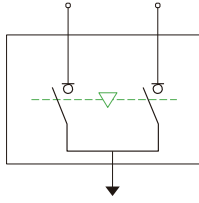

Electrical single line diagram

### Electrical characteristics

Main characteristics of WOTPC	
Class:	PC
Control mode:	ATSE

1. Performance of WOTPC 1000-4000A automatic transfer switch			
Rated current	1000-1600A	2000-2500A	3200-4000A
Number of poles	3/4	3/4	3/4
Rated operational voltage Ue:	AC 415V, 50Hz		
Rated insulation voltage Ui:	1000V		
Rated impulse withstand voltage Uimp:	12KV		
Utilization category	AC-33A		
Rated Short Time withstand current (Icw)	65kA/3s	90kA/1s	100kA/60ms
Rated short-circuit making capacity Icm:	143kA		
Electric and mechanical operation			
Electric operating cycles <sup>1</sup> :	10000	8000	8000
Mechanical operating cycles <sup>1</sup> :	20000	20000	20000
Type of transfer			
Type of transfer:	Open Transition / Delay Transition		
Controller			
LEVEL 5	■	■	■
Wiring mode			
Rear horizontal wiring	■	■	
Rear vertical wiring	□	□	■

■ Standard, □ Optional configuration

NOTE: 1. Maintainable lifespan

## Type of Transfer

WOTPC switching can satisfy the requirements of the transfer process under different load.

### Transfer with and without time delay

To ensure the safe switching of Inductive load, it must be reduced to the safe range before the transfer. Our product provides a program-controlled transfer delay mode as a solution to cope with Inductive load switching. When a time-delay switch in the process of transfer, it can be programmed to stop in a neutral position then transfer to a specific power source. The delay time can be set as 0.

Program-controlled transfer delay time can be set as 0-999S

## Number of Poles

In this product, the N line is transformed with the phase line A/B/C. The switch body with a pole number of 3P only provides the terminal of phase line A/ B/C, which is suitable for IT/TN-C grounding system. Four terminals N/A/B/C are provided for the 4P switch body, which is suitable for TN-S /TT grounding system.

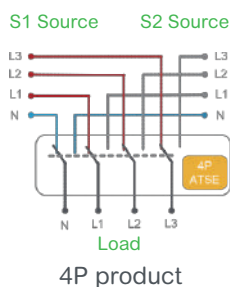
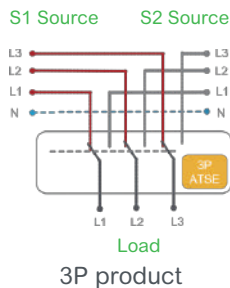



Delay conversion controller

### Overview on functions

Our ATS provides high-performance LEVEL5 controllers for power transmission, power / switch status display, auxiliary control functions, etc.

Main characteristic of LEVEL 5	
Main characteristic of LEVEL 5	
Rated voltage of controller	415 VAC
Rated operational frequency:	50/60Hz
Applicable grounding system:	TN/TT/IT
Auxiliary power supply (optional)	DC24V
Type of transfer	
Type of transfer	Open Transition / Delay Transition
Automatic transfer	
Undervoltage transfer:	S1/S2, 3 phase
Overvoltage transfer:	S1/S2, 3 phase
Open-phase transfer (Loss of Phase)	S1/S2, 3 phase
Transfer through keys of controller	
Manual key transfer – non-parallel connection:	Yes
Transfer through communication	
Communication function:	RS485
Communication protocol:	Modbus
Controller exit function	
Controller exit function	Yes
Display	
Parameter of power supply:	Voltage
State of source:	Normal / fault
State of transfer switch	State of closing of S1&S2 power supplies
Controller exit indication:	Yes
Failure:	Alarm
Setting:	Setting parameters
Advanced functions	
	RTC real time clock
	Key-lock function
	Generator start-stop control function
	Load shedding
	Main power supply setting
	Remote exit
	Failure lock function
	Event log
	Alarm function
	Language English

LEVEL 5 Controller panel

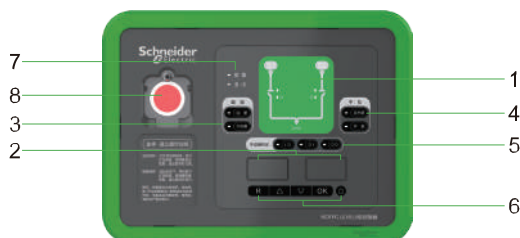

### Controller panel

- 1-Line diagram
- 2-ATSE Interactive interface
- 3-Automatic mode selection button
- 4-Manual mode selection button
- 5-Manual operation button
- 6-Set button
- 7-Indication light
- 8-Key for controller to exit function selection.

### LEVEL 5 Controller Panel

The main control panel area provides ATSE single line diagram indication, human-computer interaction interface, operation/setup buttons, function indication and exit function buttons.

- ATSE single line diagram indicates the power state of S1-S2 and the position information of the switch body
- The human-computer interaction interface consists of LCD 1 and LCD 2, providing information on S1 and S2 power supply parameters (three-phase line voltage and frequency), transfer function tips, etc. With parameter setting button, it can provide parameter setting display, alarm information reminder and other functions.
- The action button provides automatic/manual key transfer options. Two modes of operation can be selected automatically.
- The function indicator can provide fault alarm indicator and controller exit function indicator.
- The exit function button enables the controller to exit the automatic/manual button control

### User terminal area (left)

Provide advanced function wiring port, wiring reference installation and connecting user wiring port

### User terminal area (below)

Provides a control cable interface to connect the switch unit.

### User operation area (back)

Provide secondary circuit safety and operation instructions



The back of the controller



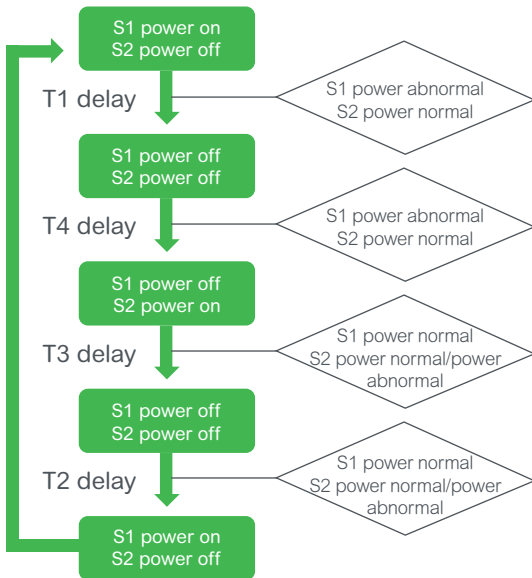

In-Delay conversion self-recovery process

LEVEL 5 controller has three different switch ontologies, which can realize the rich automatic transfer function. The controller enters the automatic operation through the automatic working mode selection. In the automatic operation process, according to the preset power detection conditions of the user, judge whether the S1/S2 power supply is normal. When the power supply fails, the controller automatically converts the power supply according to the working mode. Delays can be set during the transformation to accommodate fluctuations in the network.

LEVEL5 controller power supply detection conditions and setting range

Source detection	Source	Range	Steps
Under voltage transfer	S1/S2, 3 phase	280-360V	1V
Over voltage transfer	S1/S2, 3 phase	400-480V	1V
Open-phase transfer	S1/S2, 3 phase		

Available delay-time for LEVEL 5 controller

Delay time	Description	range	steps
T1	S1 opening delay	0-999s	1s
T2	S1 closing delay	0-999s	1s
T3	S2 opening delay	0-999s	1s
T4	S2 closing delay	0-999s	1s

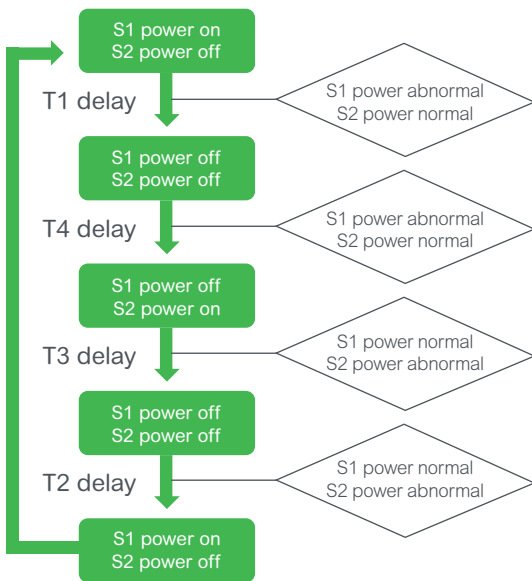

In-Delay conversion without reset process

# The Controller

## Automatic transfer

### Time-delay transfer time sequence

In the process of automatic switching, delay transfer switches can be used to transfer the high induction load by switching ON and OFF.

Non self-resetting - S1 power supply has the same priority as S2 power supply (see figure 2 - delay conversion non self-resetting process)

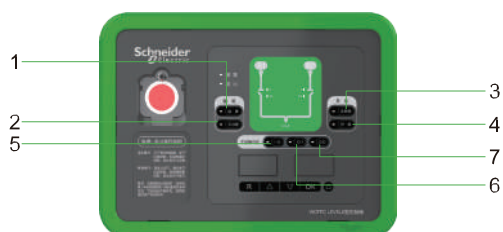

### Manual operation button

- 1-Automatic self-reset button
- 2-Automatic non-self-reset button
- 3-Manual non-parallel button
- 4-s1 close button
- 5-s1 open button
- 7-s1 close button

LEVEL5 controller allows the customer to complete the automatic operation process on site and manually switch the power to S1/S2 according to the situation on site.

The user clicks the automatic, automatic self-resetting/non self-resetting to return to the automatic operation mode.

### Manual key transfer

Under this mode, users can press button on manual operation area to switch on power supply according to the form of “opening first and then closing”. For example, users can press **I O** to switch on S1 power supply, and indicating light on the button will be on; delayed connection transfers have 3 operating modes. In manual key transfer, LEVEL5 controller will still detect state of power supply and state of transfer switch, and display state of power supply / automatic transfer switch on single line diagram / human-machine interaction LCD. In order to avoid switching on unhealthy Power supply, controller will prohibit operator from switching on fault power supply. Definition of fault power supply is consistent with to that which is set when carrying out automatic transfer.

Button	S1 Power state	S2 Power state
<b>I O</b>	1	0
<b>O I</b>	0	1
<b>O O</b>	0	0

PS: 1-closing; 0-separate

LEVEL5 controller has communication module, which can realize communication transfer. Integrated in Modbus's communication environment, four functional levels can be used individually or in combination.

### Status indicating communication (telephony)

The following information can be accessed using the communication module

- S1/S2 power input
- Working mode - automatic/manual button switching/communication switching
- Alarm state and information
- Controller exit state

### Measurement communication (telemetry)

This function provides communication of all measurement parameters

- S1/S2 supply voltage quality
- All setting parameters

### Operation management communication (remote adjustment)

This function can modify the setting parameters

- Undervoltage/overvoltage protection Settings
- Transfer time delay
- Generator start - delay time

### Command communication (remote control)

- This function can control the input of S1/S2 power supply
- The priority of the transformation mode

Manual operation > manual key conversion > remote communication conversion > automatic conversion

In order to ensure that the controller can still communicate remotely (command communication cannot be realized) when the power supply completely disappears, additional DC24V power supply needs to be provided, and the power capacity requirement is 1A.

### Installation and connection

- The remote communication module is built into the controller, which does not need to be installed on site.
- See the circuit diagram section for links
- Refer the attachment for the communication protocol of the telecommunication module



Exit button

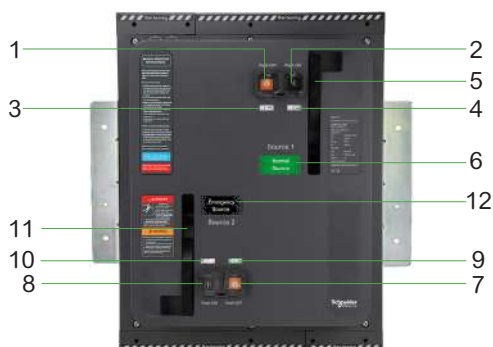

### Manual button

- 1 - S1 Power closing button and bezel lock
- 2 - S1 Power off button and bezel lock
- 3 - Indication for Status of S1 Power Supply
- 4 - Status of Energy Storage of S1 Power Supply
- 5 - Handle for Manual Energy Storage of S1 Power Supply
- 6 - S1 Power nature sign
- 7 - S2 Power closing button and bezel lock
- 8 - S2 Power off button and bezel lock
- 9 - Indication for Status of S2 Power Supply
- 10 - Status of Energy Storage of S2 Power Supply
- 11 - Handle for Manual Energy Storage of S2 Power Supply
- 12 - S2 Power nature sign

Our ATS to prevent the failure of LEVEL5 controller from affecting the power transfer, allowing users to exit the controller automatic control transfer/manual key transfer/communication transfer. After exit the controller controls, the user operates the operation button on the switch ontology. If there is no power supply, you can manually store for operation. Our ATS allows users to safely operate the switch. At the same time, the LEVEL5 controller has been monitoring the quality and input status of the S1/S2 power supply and is displayed in the SLD/HMI LCD.

### Controller exit instruction:

Exit process: open the button baffle lock and press the red button. At this time, the controller exits the controller and the exit indicator light is on. Restore operation: in the exit state, press the red button again, the controller will restore control, and the exit indicator will go out.

NOTE: After the controller exits the control, the automatic switch/manual button switch/ communication remote control switch will fail, which may cause the load to lose power.

### Manual operation instructions:

#### Manual operation (process):

1. Confirm that the controller has exited the control. If not, please open the controller exit function baffle lock and press the exit button, the exit indicator light will be on.
2. Confirm the power status of S1 and S2, the working position of the switch, and the load status.
3. Confirm that S1 and S2 power supply operating springs have stored energy. If there is no energy storage, please use the energy storage handle to store energy separately.
4. Open the button baffle lock and manually operate the switch.

Switch from S1 to S2: first press the switch button of S1 power supply, then press the switch button of S2 power supply

Switch from S2 to S1: first press the S2 power switch button, then press the S1 power switch button

### Operation instructions of controller recovery:

1. Please confirm the working position of the switch and lock the button baffle lock.
2. Confirm that the controller fuse is in the closing position.
3. Confirm the power state of S1 and S2. Press the exit button of the controller when the power supply is on, to restore the controller's control over the switch body

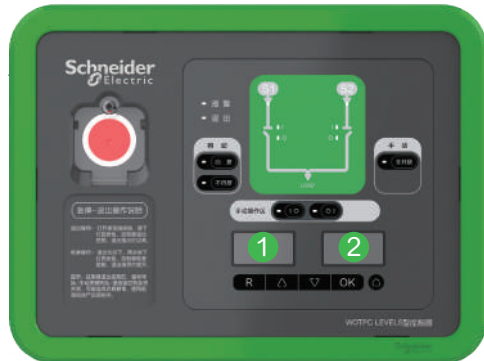

1

**Event**  
Event 01  
Event 02

1# LCD Screen

2

**Description 0 9 1**  
380 380 380  
380 380 380  
2016/07/06 16:28

2# LCD Screen

RTC real time & event recording

LEVEL5 controller also includes some unique advanced features that complement the controller's automatic transfer/ manual key transfer capabilities to enrich the ATS transfer capabilities.

### RTC Realtime

LEVEL5 controller can set actual time for site management; Actual time with occurrence recording function, can record the conversion system's actions and failures.

### Occurrence logging

LCD1 displays and switches the occurrence number (from 1 to 50) by up and down keys. LCD2 displays a selected occurrence's description.

The occurrence description is divided into four lines. The first three-digit line is the occurrence code, the high digits represent 22 occurrence types as shown below, and the lower digit represents the system state when the occurrence is triggered. Similarly, 1 - Self-adjustable state (auto), 2 - Non self-adjustable state (auto), 3 - Non-parallel state (manual).

The second line is the three-phase voltage value of the S1 power supply at the time of the event.

The third line is the three-phase voltage value of the S2 power supply at the time of the event.

The fourth line is the time of the event. The event described in figure 22: On July 6, 2016, at 16:28, when the system was working in the auto-auto-recombination state, the S2 power switch failed to alarm.

No.	Event Description	No.	Event Description
01	Closing of S1 power supply	12	Void-invalid
02	Opening of S1 power supply	13	Void-invalid
03	Alarm due to failure of closing of S1	14	Void-invalid
04	Alarm due to failure of opening of S1	15	Void-invalid
05	Void-invalid	16	Void-Invalid
06	Closing of S2 power supply	17	Void-Invalid
07	Opening of S2 power supply	18	Void-Invalid
08	Alarm due to failure of closing of S2	19	Void-Invalid
09	Alarm due to failure of opening of S2	20	Alarm due to failure of double opening
10	Void-invalid	21	Alarm due to double closing
11	Void-invalid	22	Halted at wrong position

### Key locking function

If there is no operation, the controller will automatically enter the button lock state after 120s to avoid user operation errors. In the locked state, LEVEL5 controller does not allow automatic/manual keystrokes/parameter Settings. To unlock this feature, press button 3s.

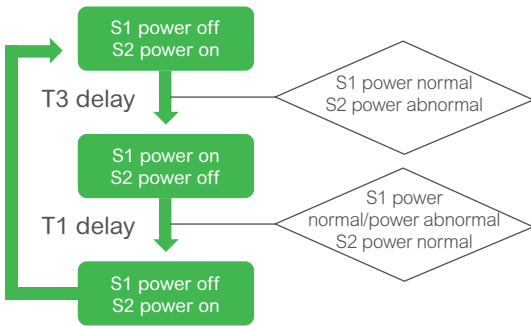

Choosing S2 as the main power supply self-recovery workflow

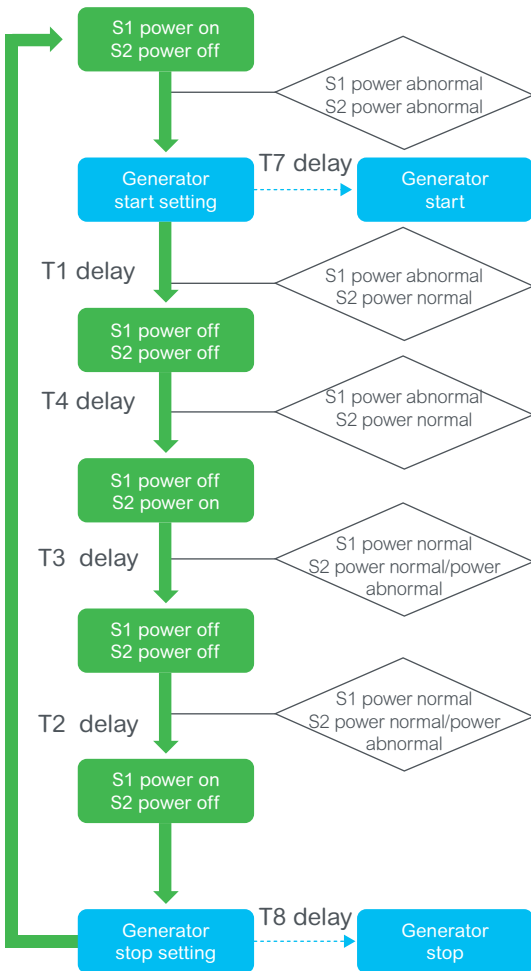

Generator start and stop control process

### Main power selection

LEVEL5 controller allows users to change the input order by setting the main power supply. If the S2 power supply is set as the main power supply, the automatic transfer will give priority to the input of the S2 power supply (self-adjusting/non self-adjusting process change). The changing process is shown in figure to select the self-adjusting process of S2 as the main power supply. After the main power supply is changed to the S2 power supply, the following functions are changed:

- Automatic transfer
- Generator start/ stop control
- Load/ Unload

### Generator start - stop control function

In the case of power supply failure, the LEVEL5 controller can provide a set of generator start-stop control nodes to enable the generator to start automatically. When Generator power is restored, ATS is automatically connected to the generator power supply. When the main power supply is restored and returns to the main power supply, the start-stop control node of the generator will switch to the state, making the generator stop automatically.

Start/stop delay can be set to avoid the main power fluctuation. The delay can be set to (if S2 is set as the primary power, the conditions for the delay to take effect change).

Main power supply	Delay time	Description	Range	Steps
S1	T7	Generator starting delay	0-999s	1s
	T8	Generator closing delay	0-999s	1s
S2	T7	Generator starting delay	0-999s	1s
	T8	Generator closing delay	0-999s	1s

To make the controller still able to issue the T7 delay in the case of power failure, it needs to be provided with the power supply capacity of DC24V, 1A.

The start-stop control flow of the generator is shown in Figure 7 NOTE: The above process adopts the self-replicating process.

### Load shedding function

Since the capacity of the generator may be smaller than that of the utility, when the generator provides the load, it will not be able to meet all the loads. At this point, the LEVEL5 controller can provide unloading contacts to cut off non-essential loads.

The unloading contact capacity is AC220V 5A. If the main power is selected as S1, the contact action occurs if S1 power is abnormal. If S2 is selected as the primary power supply, a contact action occurs in the event of an S2 power failure.

# WOTPC

WOTPC Series ATS

# The Controller

Advanced functions

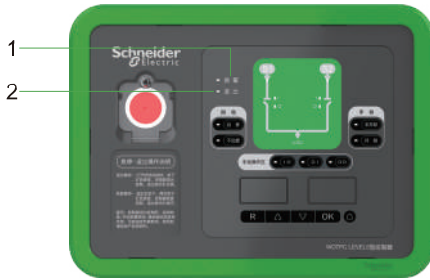

Indicator light

1-Alarm indicator

2-Exit indicator

## Remote exit

The LEVEL5 controller can remotely perform the exit operation of the controller through the additional dry contact node, with the control loop no more than 100m.

When the dry contact node signal remains off, the controller exits the control; When the dry contact node signal remains on, the controller resumes control. The remote exit status is consistent with the ability to exit the controller using the manual button.

## Fault lock function

The LEVEL5 controller will automatically lock the implementation of transfer of transfer switch and an alarm will be issued in the following state:

- Transition failure (controller instructions do not correspond to the state of the transfer switch itself).

## Alarm function

When WOTPC automatic transfer switch is in the state of fault lock, and the controller emits sound and light alarm.

# Interlocking

Our ATS provides electrical and mechanical interlocks to ensure the S1/S2 power supply does not run side by side.

## Electrical interlocking

The LEVEL5 controller has an electrical interlock circuit to ensure the safety of the power supply. Includes the following electrical interlocking functions:

- A logic lock is built in the controller to avoid sending the S1/S2 power input signal wrongly.

## Mechanical interlocking

Our ATS built-in mechanical interlock can effectively ensure that the S1/S2 power supply will not run side by side irrespective of electrical interlock.

Our transfer switches are already built-in with electrical and mechanical interlocks and no additional installation is required.



Mechanical chain

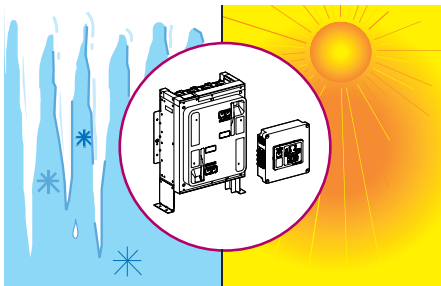

Environmental condition

Our ATS uses enhanced technology to ensure it adapts to the surrounding complex atmospheric environment.

### Ambient air temperature:

- It shall not exceed 70°C
- The lower limit under normal temperature is -25°C

### Storage temperature

The ambient air temperature does not exceed 85°C

The lower limit of ambient air temperature is -40°C

### Altitude

When the altitude is lower than 2000m, the characteristics of automatic power transfer system are not affected.

### Humidity

It meets the verification requirements of GB/T2423.4-2008, test Db, 2 cycles, +55°C, method 2

### Pollution degree

Pollution degree levels are 4

### Salt-spray level

GB/T2423.18-2000, test Kb, severity 1

### Impact and vibration

The vibration test meets the requirements of GB/T2423.10-2008 test Fc Impact test meets GB/T2423.5-1995 test Fa

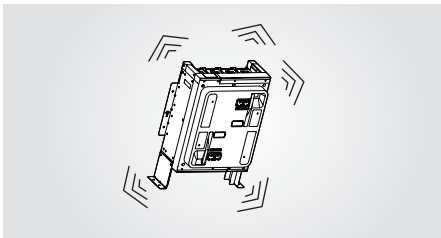

Vibraion



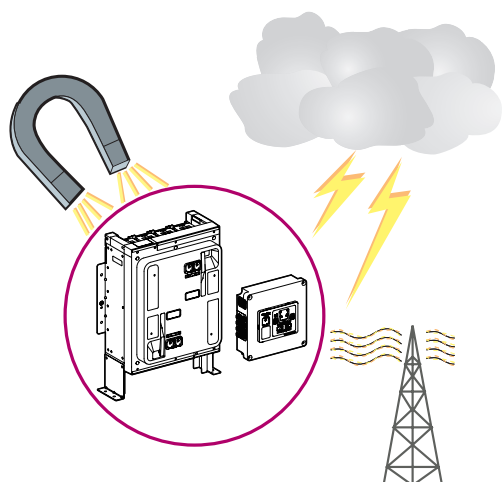

### Introduction to Electromagnetic Compatibility

Electromagnetic compatibility refers to the ability of a device or system to operate normally in its electromagnetic environment without causing intolerable electromagnetic disturbance to anything in that environment.

The EMC test is divided into two test sections

- Resistance test

A device or system capable of operating in the presence of electromagnetic interference without degrading its performance.

- Emission

The emission of electromagnetic energy from a source.

Our controllers meet and exceed GB/T14048.11-2016 automatic switching product standards. This ensures that the power supply and control circuit will not fail under the following electromagnetic interference.

### Resistance

Test	Standard	1000 - 4000A
Electrostatic discharge immunity test	GB/T 17626.2	Level 3
Radio-frequency electromagnetic fields	Conducted radio-frequency immunity test	GB/T 17626.6 Level 3
	Radiated radio-frequency electromagnetic field immunity test	GB/T 17626.3 Level 3
Electrical fast transient/burst immunity test	GB/T 17626.4	Level 4
Surge immunity test	GB/T 17626.5	Level 4
Harmonic voltage immunity test	GB/T 17626.13	Level 3

Test	Standard	Grade	Performance
Conducted radiofrequency emission tests	GB4824	pass	Class A/B
Radiated radiofrequency emission tests	GB4824	pass	Class A/B

WOTPC series transfer switch unit is installed in the distribution cabinet

### Allowed Installation Position

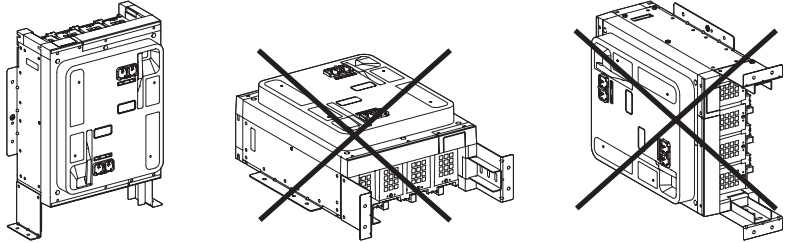

Forward direction installation

Two installation methods:

- Install on vertical guide rail or drawbar with flat mounting surface (error within 2mm).
- Install on vertical guide rail or drawbar and install on horizontal guide rail or substrate with flat mounting surface (error within 2mm).

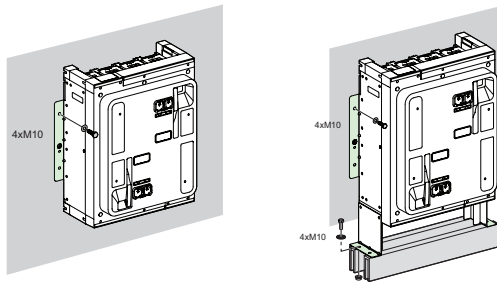

Our product family of transfer switches provides two types of connection busbars - vertical and horizontal. Users of products 2500A and below can choose a horizontal or vertical connection from the order, while products 3200-4000A can only provide vertical connection; When the horizontal wiring is changed to vertical wiring in the field, the copper bar of S1/S2 power connection can be rotated freely in the field. Also, the load side of the vertical wiring copper bar can be ordered to install (load side of the vertical wiring copper bar can be ordered to install).

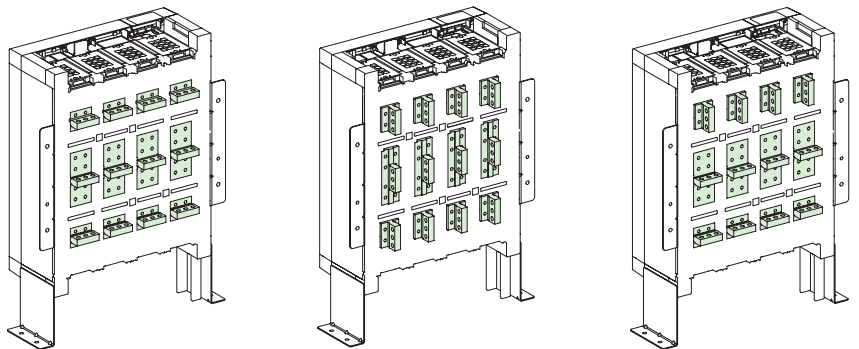

Horizontal/vertical exchange of copper bars

To increase the safe distance between phases, our ATS provides the interphase baffles (accessory).

### Size and Weight

Number of poles	1000-2500A		3200-4000A	
	Dimensions (mm) W*H*D	Weight (kg)	Dimensions (mm) W*H*D	Weight (kg)
3P	640*840*340	118	640*840*340	121
4P	640*840*340	129	640*840*340	132

## Forward direction installation

WOTPC ATS unit 1000-4000A has the same dimensions

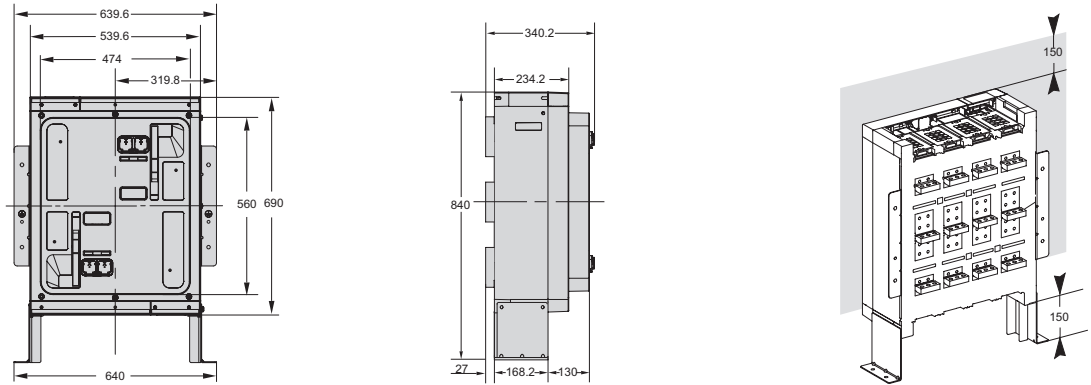

Safety clearance

More than 150mm shall be kept above and below the arc extinguishing chamber of ATS unit

## Installation and positioning

4P/N3 Product positioning hole

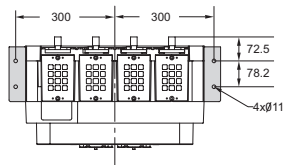

3P Product positioning hole

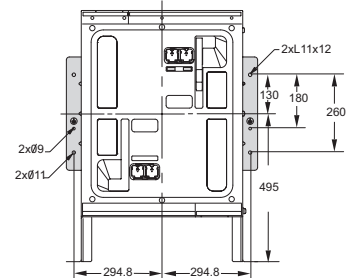
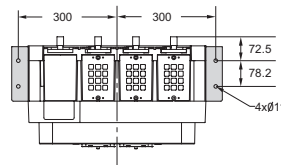

## The corresponding partition

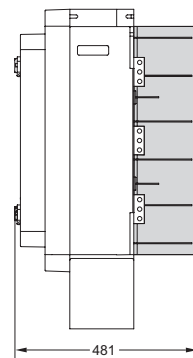
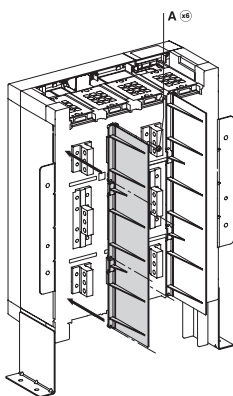

The corresponding partition

## 4P horizontal connection

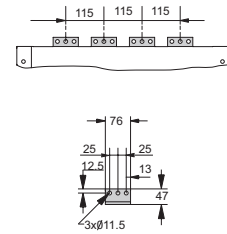
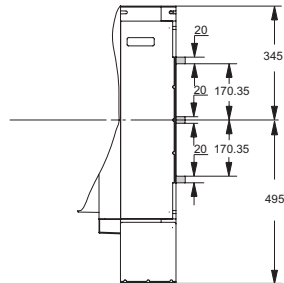
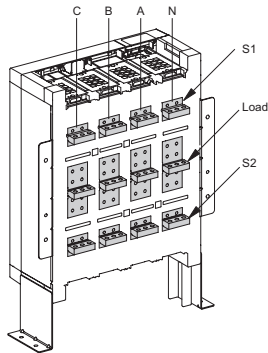

## 3P horizontal connection

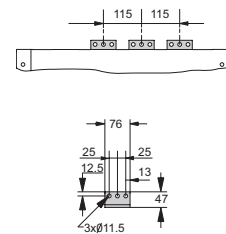
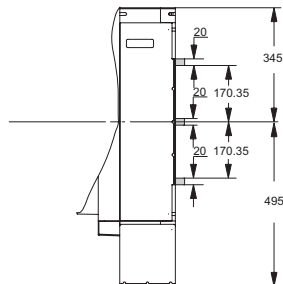
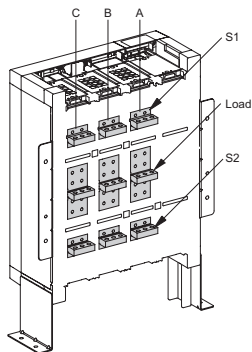



## 4P vertical connection

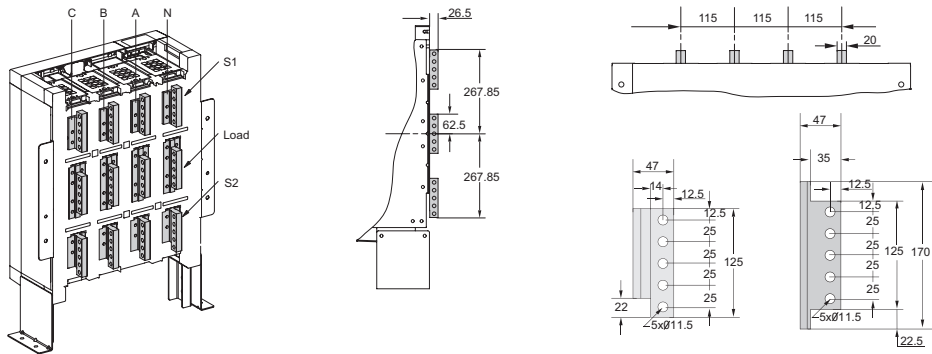

## 3P vertical connection

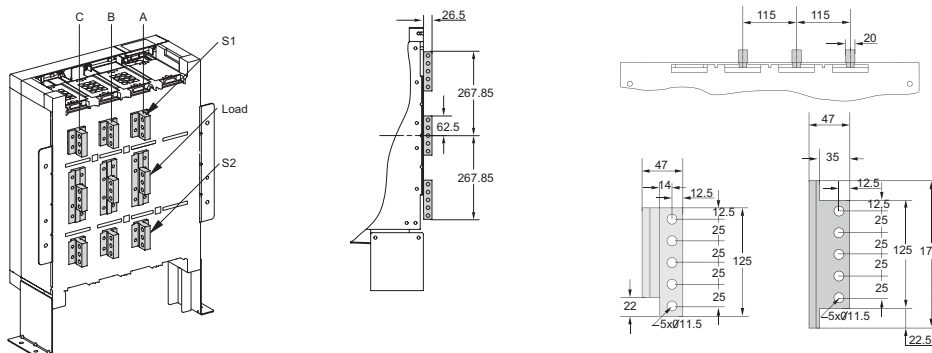

# Setup and connect

## Installation of the controller

The LEVEL5 controller is installed on the front panel of the cabinet and fixed through the mounting hole installed on the controller board. M8 bolts may be welded to the inside of the front panel for fixation or M8 bolts (length >50mm, not exceeding 60mm is recommended) may be drilled to the inside of the front panel for fixation. The controller is heavy, please pay attention to the thickness and load-bearing of the cabinet panel.

A space of at least 50mm shall be left between the front panel of the cabinet and the internal objects for controller installation and wiring. In the cabinet before the panel open holes, exposed the main control panel area.

### Controller dimension table

Controller	Type of transfer	Width(mm)	Height (mm)	Depth (mm)	Weight(kg)
LEVEL 5	Delay transition	360	360	109	5Kg

### Controller external dimension

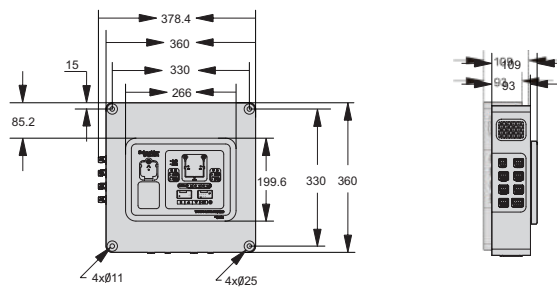

### Installation and fixation of the controller

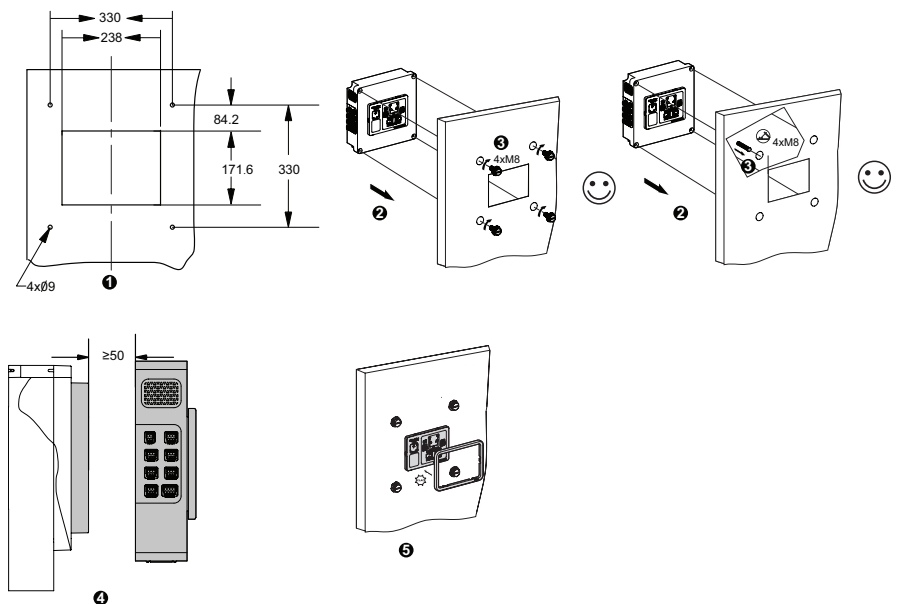

# Setup and connect

## Connection of wiring cables

Our ATS adopts controller cable connection, LEVEL5 controller, and switch unit. A total of four controller cables are connected to the top left of the switch unit and bottom of the controller.

To ensure the correct wiring of the field, the anti-mis insertion design is adopted; the length of the controller cable is 2m.

To extend the length of the control cable, please specify in the order or order additional controller extension cable (length 4m).

NOTE: To order extension cable, please contact Schneider Marketing Department in advance.

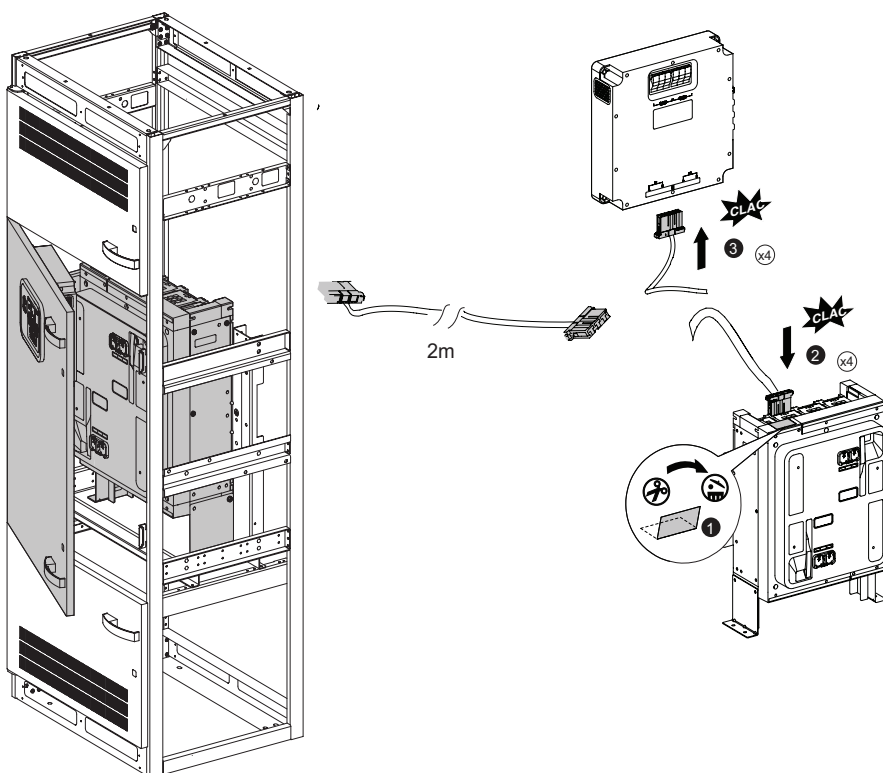

Name of wire	Sampling wire for S1	Controlling wire for S1	Sampling wire for S2	Controlling wire for S2
Number of terminals	3	12	3	12
Wire No.	S1-A	S1-B	S2-A	S2-B
Length of wire	2M	2M	2M	2M



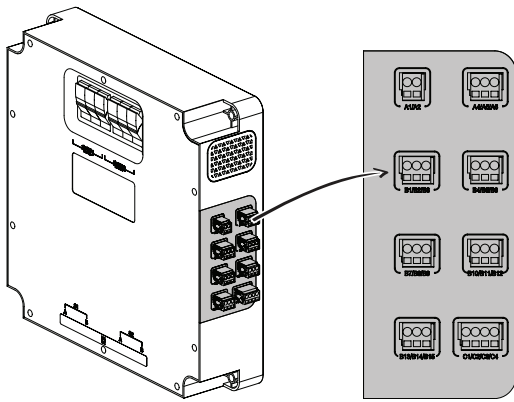

Side of controller

Our ATS provides multiple sets of user terminals for advanced functions, located to the left of LEVEL5 Controller

The minimum cross-sectional area of terminals is 0.6 mm<sup>2</sup> and the maximum cross-sectional area is 2.5 mm<sup>2</sup>

No.	Name	Terminal No.	Terminal Capacity
01	DC24V auxiliary source	A1/2	<1A
02	Alarm	A4/5/6	AC250V 3A
03	Position feedback for S1	B1/2/3	AC250V 1.5A
04	Load shedding	B4/5/6	AC250V 3A
05	Position feedback for S2	B7/8/9	AC250V 1.5A
06	Generator start-stop control signal	B10/11/12	AC250V 3A
07	Input for remote exit	B13/14/15	
08	Communication	C1/2/3/4	

### Electrical wiring diagram

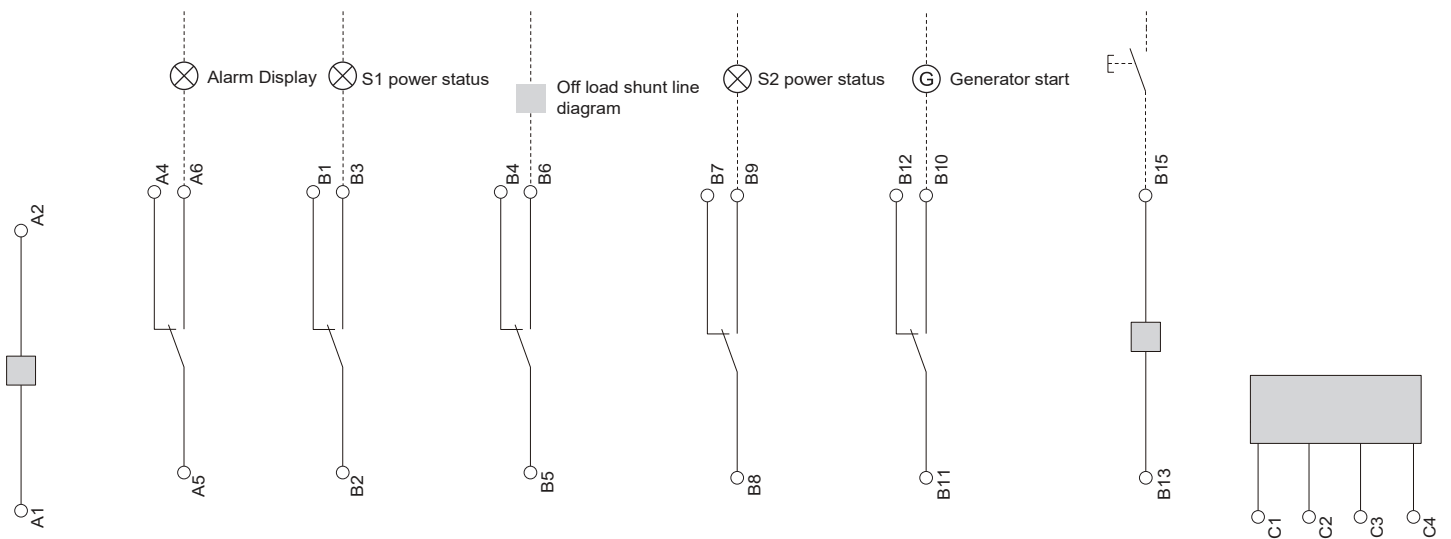

A1: DC24V auxiliary power +  
A2: DC24V auxiliary power -

A4/5: Open when the closed node alarms  
A6/5: Closed when the open node alarms

B1/2: Closed node S1 opens when the power supply is closed  
B3/2: Open node S1 is closed when the power supply is closed

B4/5: Closed node opens when it sends an unload signal  
B6/5: Closed when the open node issues unload signal

B7/8: Normally closed node S2 opens when the power supply is closed  
B9/8: Closed when the open node S2 power supply is closed

B10/11: Closed when the open node sends generator start signal;  
Turn on when the generator is signaled to stop

B12/11: Turn on when the closed node sends generator start signal;  
Close when sending the generator stop signal

B13/15: The input closing signal controller performs the exit operation  
Input open signal controller to restore control

C1: Ground

C2: Shield

C3: B

C4: A

# Appendix I

Level5 types controller communication protocol

Address (DEC)	Parameters	Description	Functional code	Access rule
0	Switch Status of S1	0 open, 1 close 2 empty address	3	read
1	Switch Status of S1	0 open, 1 closed, 2 empty address	3	read
2	Retained		3	read
3	Voltage of U <sub>AB</sub> of S1		3	read
4	Voltage of U <sub>BC</sub> of S1		3	read
5	Voltage of U <sub>CA</sub> of S1		3	read
6	Voltage of U <sub>AB</sub> of S2		3	read
7	Voltage of U <sub>BC</sub> of S2		3	read
8	Voltage of U <sub>CA</sub> of S2		3	read
9	Frequency of S1		3	read
10	Frequency of S2		3	read
11	Phase-angle difference A of S1&S2		3	read
12	Phase-angle difference B of S1&S2		3	read
13	Phase angle difference C of S1&S2		3	read
14	Exiting controller	0 controller on, 1 controller off	3	read
15	Retained		3	read
16	Retained		3	read
17	Alarm	1 normal, 2 alarm	3	read
18	Status of S1	0 unavailable, 1 available	3	read
19	Status of S2	0 unavailable, 1 available	3	read
20	Threshold value of undervoltage	280-360V	3, 6	read/writing
21	Threshold value of overvoltage	420-480V	3, 6	read/writing
22	Retained		3, 6	read/writing
23	Retained		3, 6	read/writing
24	Delay time T1	Opening delay of main source 0S-999S	3, 6	read/writing
25	Delay time T2	Closing delay of main source 0S-999S	3, 6	read/writing
26	Delay time T3	Opening delay of emergency source 0S-999S	3, 6	read/writing
27	Delay time T4	Closing delay of emergency source 0S-999S	3, 6	read/writing
28	Retained		3, 6	read/writing
29	Retained		3, 6	read/writing
30	Delay time T7	Generator starting delay 0S-999S	3, 6	read/writing
31	Delay time T8	Generator cooldown delay 0S-999S	3, 6	read/writing
32	Retained		3, 6	read/writing
33	Retained		3, 6	read/writing
34	Communication address	1-64	3, 6	read/writing
35	Baud rate	0, 9600, 1, 19200	3, 6	read/writing
36	Parity check	0 none, 1 even, 2 odd	3, 6	read/writing
37	Event log	0 close, 1 open	3, 6	read/writing
38	Selection of application mode	0 U-U 1 U-G	3, 6	read/writing
39	Operating mode	1 automatic-self-reset, 2 automatic- non-self-reset 3 manual-non-parallel connection, 5 communication control	3, 6	read/writing
40	Language	1 English	3, 6	read/writing
41	Date	1yy/mm/dd, 2 mm/dd/yy, 3 dd/mm/yy	3, 6	read/writing
42	Year setting	00-99	3, 6	read/writing
43	Month setting	01-12	3, 6	read/writing
44	Day setting	01-31	3, 6	read/writing
45	Hour setting	00-23	3, 6	read/writing
46	Minute setting	00-59	3, 6	read/writing
47	Record1-year		3	read
48	Record1-month		3	read
49	Record1-day		3	read
50	Record1-hour		3	read
51	Record1-minute		3	read
52	Record1-action or faultcode		3	read
53	Record1- U <sub>AB</sub> of S1		3	read
54	Record1- U <sub>BC</sub> of S1		3	read
55	Record1- U <sub>CA</sub> of S1		3	read
56	Record1- U <sub>AB</sub> of S2		3	read
57	Record1- U <sub>BC</sub> of S2		3	read
58	Record1- U <sub>CA</sub> of S2		3	read
59	Record2-year		3	read
60	Record2-month		3	read
61	Record2-day		3	read

Address (DEC)	Parameters	Description	Functional code	Access rule
62	Record2-hour		3	read
63	Record2-minute		3	read
64	Record2-action or faultcode		3	read
65	Record2- U <sub>AB</sub> of S1		3	read
66	Record2- U <sub>BC</sub> of S1		3	read
67	Record2- U <sub>CA</sub> of S1		3	read
68	Record2- U <sub>AB</sub> of S2		3	read
69	Record2- U <sub>BC</sub> of S2		3	read
70	Record2- U <sub>CA</sub> of S2		3	read
71	Record3-year		3	read
72	Record3-month		3	read
73	Record3-day		3	read
74	Record3-hour		3	read
75	Record3-minute		3	read
76	Record3-action or faultcode		3	read
77	Record3- U <sub>AB</sub> of S1		3	read
78	Record3- U <sub>BC</sub> of S1		3	read
79	Record3- U <sub>CA</sub> of S1		3	read
80	Record3- U <sub>AB</sub> of S2		3	read
81	Record3- U <sub>BC</sub> of S2		3	read
82	Record3- U <sub>CA</sub> of S2		3	read
83	Record4- year		3	read
84	Record4- month		3	read
85	Record4- day		3	read
86	Record4- hour		3	read
87	Record4- minute		3	read
88	Record4- action or fault code		3	read
89	Record4- U <sub>AB</sub> of S1		3	read
90	Record4- U <sub>BC</sub> of S1		3	read
91	Record4- U <sub>CA</sub> of S1		3	read
92	Record4- U <sub>AB</sub> of S2		3	read
93	Record4- U <sub>BC</sub> of S2		3	read
94	Record4- U <sub>CA</sub> of S2		3	read
95	Record5-year		3	read
96	Record5-month		3	read
97	Record5-day		3	read
98	Record5-hour		3	read
99	Record5-minute		3	read
100	Record5- action or fault code		3	read
101	Record5- U <sub>AB</sub> of S1		3	read
102	Record5- U <sub>BC</sub> of S1		3	read
103	Record5- U <sub>CA</sub> of S1		3	read

## VRAJ LINK

House of Changeover & Automatic transfer switch

DIPENBHAI KADAKIA  
+91-9619800070

CHIRAGBHAI KADAKIA  
+91-9833935831

Email : [vrajlink09@gmail.com](mailto:vrajlink09@gmail.com)

Tel. No. 022 - 22076173 / 09223310978

AUTHORISED DISTRIBUTORS



Admin Off. : Shop No. 17, Opp. Electric Crematorium 66/74  
Chandan Wadi, Marine Lines (E), Mumbai - 400 003.